



BUILDING CODE COMPLIANCE OFFICE (BCCO)  
PRODUCT CONTROL DIVISION

MIAMI-DADE COUNTY, FLORIDA  
METRO-DADE FLAGLER BUILDING  
140 WEST FLAGLER STREET, SUITE 1603  
MIAMI, FLORIDA 33130-1563  
(305) 375-2901 FAX (305) 375-2908

**NOTICE OF ACCEPTANCE (NOA)**

[www.buldingcodeonline.com](http://www.buldingcodeonline.com)

**Arso Enterprises dba Sol-A-Trol Aluminum Products**  
4101 NW 132<sup>nd</sup> Street  
Miami, FL 33054

**SCOPE:**

This NOA is being issued under the applicable rules and regulations governing the use of construction materials. The documentation submitted has been reviewed by Miami-Dade County Product Control Division and accepted by the Board of Rules and Appeals (BORA) to be used in Miami Dade County and other areas where allowed by the Authority Having Jurisdiction (AHJ).

This NOA shall not be valid after the expiration date stated below. The Miami-Dade County Product Control Division (In Miami Dade County) and/or the AHJ (in areas other than Miami Dade County) reserve the right to have this product or material tested for quality assurance purposes. If this product or material fails to perform in the accepted manner, the manufacturer will incur the expense of such testing and the AHJ may immediately revoke, modify, or suspend the use of such product or material within their jurisdiction. BORA reserves the right to revoke this acceptance, if it is determined by Miami-Dade County Product Control Division that this product or material fails to meet the requirements of the applicable building code.

This product is approved as described herein, and has been designed to comply with the Florida Building Code, including the High Velocity Hurricane Zone.

**DESCRIPTION: Series 535 Aluminum Single Hung Window – L.M.I.**

**APPROVAL DOCUMENT:** Drawing No. **W06-16**, titled "Series 535 Aluminum Single Hung Wdw. (L.M.I.)", sheets 1 through 7 of 7, dated 03/05/06, prepared by Al-Farooq Corporation, signed and sealed by Humayoun Farooq, P.E., bearing the Miami-Dade County Product Control Approval stamp with the Notice of Acceptance number and approval date by the Miami-Dade County Product Control Division.

**MISSILE IMPACT RATING: Large and Small Missile Impact Resistant**

**LABELING:** Each unit shall bear a permanent label with the manufacturer's name or logo, city, state and following statement: "Miami-Dade County Product Control Approved", unless otherwise noted herein.

**RENEWAL** of this NOA shall be considered after a renewal application has been filed and there has been no change in the applicable building code negatively affecting the performance of this product.

**TERMINATION** of this NOA will occur after the expiration date or if there has been a revision or change in the materials, use, and/or manufacture of the product or process. Misuse of this NOA as an endorsement of any product, for sales, advertising or any other purposes shall automatically terminate this NOA. Failure to comply with any section of this NOA shall be cause for termination and removal of NOA.

**ADVERTISEMENT:** The NOA number preceded by the words Miami-Dade County, Florida, and followed by the expiration date may be displayed in advertising literature. If any portion of the NOA is displayed, then it shall be done in its entirety.

**INSPECTION:** A copy of this entire NOA shall be provided to the user by the manufacturer or its distributors and shall be available for inspection at the job site at the request of the Building Official.

This NOA consists of this page 1 and evidence pages E-1 and E-2, as well as approval document mentioned above.

The submitted documentation was reviewed by **Manuel Perez, P.E.**



**NOA No. 06-0911.02**  
**Expiration Date: March 15, 2012**  
**Approval Date: March 15, 2007**  
**Page 1**

Arso Enterprises dba Sol-A-Trol Aluminum Products

NOTICE OF ACCEPTANCE: EVIDENCE SUBMITTED

**A. DRAWINGS**

1. Manufacturer's die drawings and sections.
2. Drawing No **W06-16**, Sheets 1 through 7 of 7, titled "Series 535 Aluminum Single Hung Wdw. (L.M.I.)", dated 03/05/06, prepared by Al-Farooq Corporation, signed and sealed by Humayoun Farooq, P.E.

**B. TESTS**

1. Test reports on: 1) Air Infiltration Test,  
2) Uniform Static Air Pressure Test,  
3) Water Resistance Test,  
4) Forced Entry Test, per SFBC 3603.2 (b)  
along with marked-up drawings and installation diagram of a mulled single hung and fixed window, glazed with 21/64" and 5/16" HS. glass, prepared by Hurricane Engineering and Testing Laboratory, Inc., Test Report No. **HETI-04-1398**, dated 07/22/04, signed and sealed by Ivonne Ghia, P.E.
2. Test reports on: 1) Large Missile Impact Test per FBC, TAS 201-94  
2) Cyclic Wind Pressure Loading per FBC, TAS 203-94  
along with marked-up drawings and installation diagram of a mulled single hung and fixed window, glazed with 5/16" and 7/16" HS laminated glass, prepared by Hurricane Engineering and Testing Laboratory, Inc., Test Report No. **HETI-05-1912**, dated 12/21/05, signed and sealed by Gilbert Diamond, P.E.
3. Test reports on: 1) Air Infiltration Test,  
2) Uniform Static Air Pressure Test,  
3) Water Resistance Test,  
4) Forced Entry Test, per SFBC 3603.2 (b)  
along with marked-up drawings and installation diagram of a mulled single hung and fixed window, glazed with 7/16" ANN. glass, prepared by Hurricane Engineering and Testing Laboratory, Inc., Test Report No. **HETI-05-1460**, dated 08/05/05, signed and sealed by Ivonne Ghia, P.E.
4. Test reports on: 1) Large Missile Impact Test per FBC, TAS 201-94  
2) Cyclic Wind Pressure Loading per FBC, TAS 203-94  
along with marked-up drawings and installation diagram of a mulled single hung and fixed window, glazed with 7/16" ANN. laminated glass, prepared by Hurricane Engineering and Testing Laboratory, Inc., Test Report No. **HETI-05-2056**, dated 12/14/05, signed and sealed by Ivonne Ghia, P.E.
5. Test reports on: 1) Large Missile Impact Test per FBC, TAS 201-94  
2) Cyclic Wind Pressure Loading per FBC, TAS 203-94  
along with marked-up drawings and installation diagram of a mulled single hung and fixed window, glazed with 7/16" ANN. laminated glass, prepared by Hurricane Engineering and Testing Laboratory, Inc., Test Report No. **HETI-05-1966**, dated 11 /14/05, signed and sealed by Ivonne Ghia, P.E.

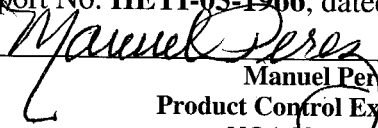
  
Manuel Perez, P.E.  
Product Control Examiner  
NOA No. 060911.02  
Expiration Date: March 15, 2012  
Approval Date: March 15, 2007

Arso Enterprises dba Sol-A-Trol Aluminum Products

NOTICE OF ACCEPTANCE: EVIDENCE SUBMITTED

6. Test reports on: 1) Large Missile Impact Test per FBC, TAS 201-94  
2) Cyclic Wind Pressure Loading per FBC, TAS 203-94  
along with marked-up drawings and installation diagram of two mulled single hung windows, glazed with 7/16" HS laminated glass, prepared by Hurricane Engineering and Testing Laboratory, Inc., Test Report No. **HETI-06-2095**, dated 05/02/06, signed and sealed by Ivonne Ghia, P.E.
- C. CALCULATIONS**
1. Anchor verification calculations and structural analysis, complying with FBC-2004, prepared by Al-Farooq Corporation, dated 5/25/06, signed and sealed by Humayoun Farooq, P.E.  
**Complies with ASTM E1300-98 and 02.**
- D. QUALITY ASSURANCE**
1. Miami Dade Building Code Compliance Office (BCCO).
- E. MATERIAL CERTIFICATIONS**
1. Notice of Acceptance No. **01-1204.01** issued to E.I. DuPont DeNemours for "**Sentry Glass (R) Plus**" dated 01/17/02, expiring on 01/14/07.  
2. Notice of Acceptance No. **03-0415.13** issued to Solutia Inc. for their "**Vanceva Composites used for lamination of glass**" dated 12/11/03, expiring on 12/11/08.  
3. Notice of Acceptance No. **04-0816.02** issued to E.I. DuPont DeNemours for "**DuPont Butacite "ST" PVB Material**" dated 02/04/05, expiring on 02/04/10.  
4. Notice of Acceptance No. **01-0205.02** issued to Solutia Inc. for their "**Saflex /Keepsafe Maximum**" dated 05/17/01, expiring on 05/21/06.
- F. STATEMENTS**
1. Statement letter of conformance, dated May 23, 2006, signed and sealed by Humayoun Farooq, P.E.  
2. Statement letter of no financial interest, dated May 23, 2006, signed and sealed by Humayoun Farooq, P.E.
- G. OTHER**
1. None.

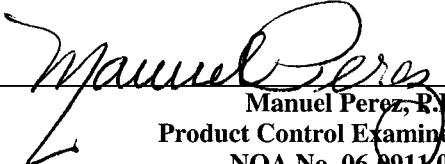
  
Manuel Perez, P.E.  
Product Control Examiner  
NOA No. 06-0911.02  
Expiration Date: March 15, 2012  
Approval Date: March 15, 2007

THESE WINDOWS ARE RATED FOR LARGE MISSILE IMPACT.  
SHUTTERS ARE NOT REQUIRED.

**SERIES 535 ALUMINUM SINGLE HUNG WDW.**

DESIGN LOAD RATING FOR THESE WINDOWS TO BE AS PER CHARTS SHOWN ON SHEET 2.

APPROVAL APPLIES TO SINGLE UNITS OR SIDE BY SIDE COMBINATIONS OF S.H./S.H. OR SINGLE HUNG WITH OTHER WINDOW TYPES IN MODULES OF TWO OR MORE WINDOWS USING MIAMI-DADE COUNTY APPROVED MULLIONS IN BETWEEN. LOWER DESIGN PRESSURE FROM WINDOWS OR MULLION APPROVAL WILL APPLY TO ENTIRE SYSTEM.

THIS PRODUCT HAS BEEN DESIGNED AND TESTED TO COMPLY WITH THE REQUIREMENTS OF THE FLORIDA BUILDING CODE 2004 EDITION (REV. 2005) INCLUDING HIGH VELOCITY HURRICANE ZONE (HVHZ).

WOOD BUCKS BY OTHERS, MUST BE ANCHORED PROPERLY TO TRANSFER LOADS TO THE STRUCTURE.

ANCHORS SHALL BE AS LISTED, SPACED AS SHOWN ON DETAILS, ANCHORS EMBEDMENT TO BASE MATERIAL SHALL BE BEYOND WALL DRESSING OR STUCCO.

ANCHORING OR LOADING CONDITIONS NOT SHOWN IN THESE DETAILS ARE NOT PART OF THIS APPROVAL.

A LOAD DURATION INCREASE IN ALLOWABLE STRESS IS USED IN DESIGN OF ANCHORS INTO WOOD ONLY.

MATERIALS INCLUDING BUT NOT LIMITED TO STEEL SCREWS, THAT COME INTO CONTACT WITH OTHER DISSIMILAR MATERIALS SHALL MEET THE REQUIREMENTS OF 2004 FLORIDA BLDG. CODE SECTION 2003.8.4 (SUPPLEMENT 2005).

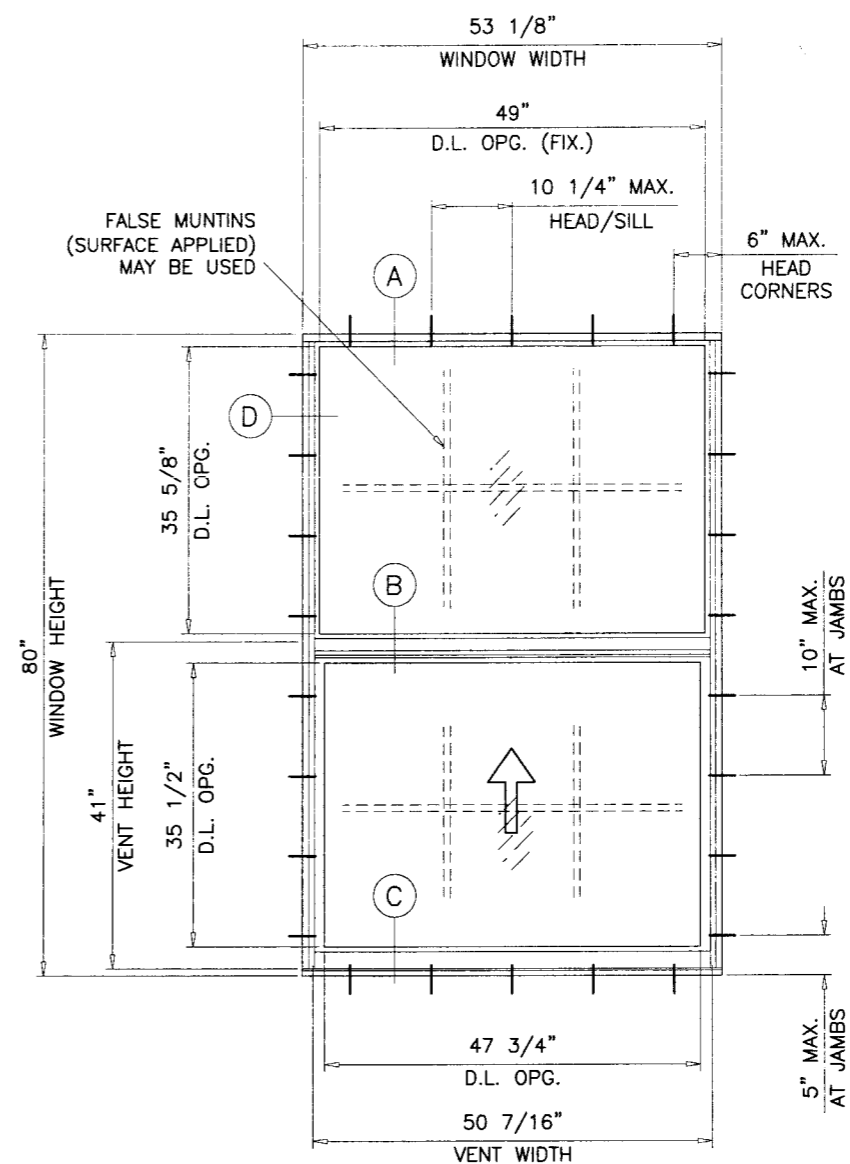

**TYPICAL ELEVATION**  
TESTED UNIT

LAMINATED GLASS  
LARGE MISSILE IMPACT

Engr: DR. HUMAYOUN FAROOQ  
STRUCTURES  
FLA. PE # 16557  
C.A.N. 3538  
AUG 07 2006

Approved as complying with the  
Florida Building Code  
Date MARCH 15, 2007  
NOA# 06-0911-02  
Miami Dade Product Control  
Division  
By: *[Signature]*

*afc*

**AL-FAROOQ CORPORATION**  
ENGINEERS, PLANNERS & PRODUCT DESIGN  
1235 SW 87 AVE  
MIAMI, FLORIDA 33174  
TEL. (305) 264-8100 FAX. (305) 262-6978  
COMP-ANL\W06-16SAT

SERIES 535 ALUMINUM SINGLE HUNG WDW. (L.M.I.)

**SOL-A-TROL ALUMINUM PRODUCTS**  
4101 N.W. 132ND STREET  
MIAMI, FL. 33054  
TEL. (305) 681-2020 FAX. (305) 681-2035

| no | date | by | description |
|----|------|----|-------------|
|    |      |    |             |
|    |      |    |             |
|    |      |    |             |

date: 03-05-06  
scale: 1/2"=1'-0"  
dr. by: HAMID  
chk. by:

drawing no.  
**W06-16**

sheet 1 of 7

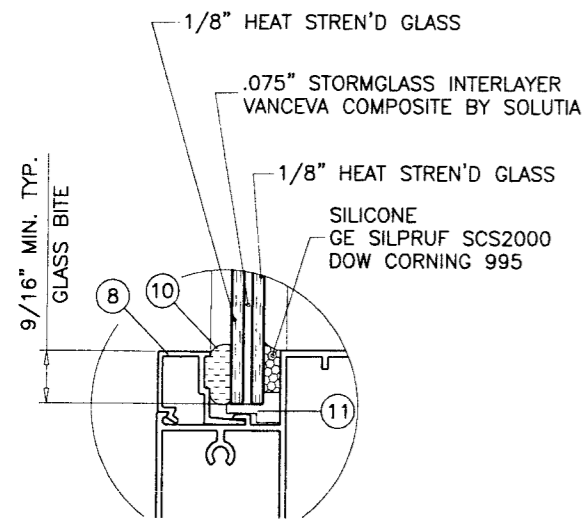

GLASS TYPE 'A'

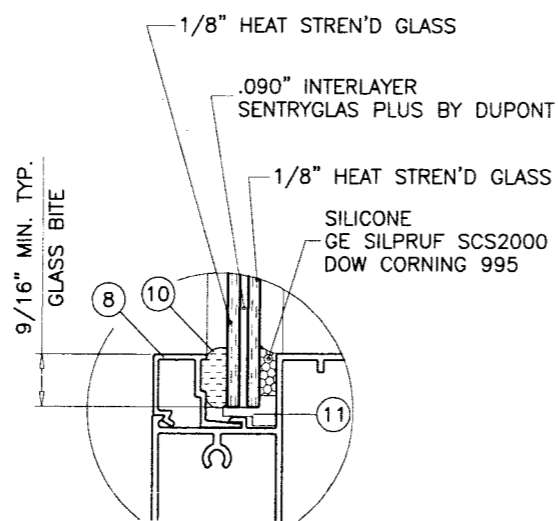

GLASS TYPE 'B'

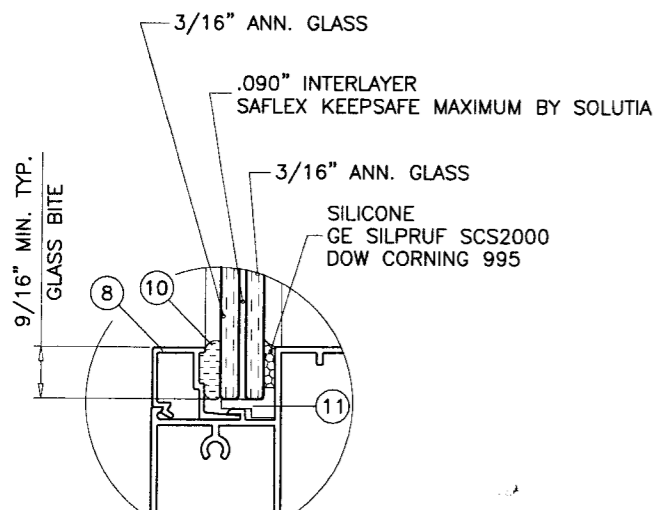

GLASS TYPE 'C'

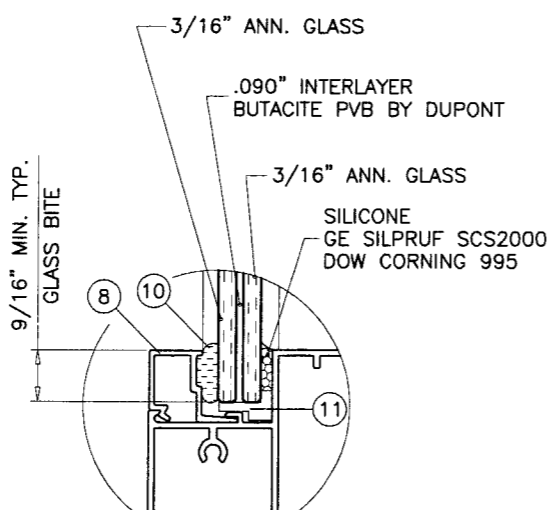

GLASS TYPE 'D'

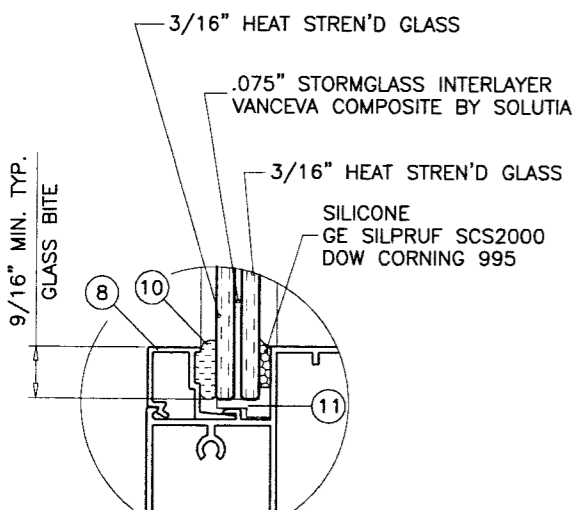

GLASS TYPE 'E'

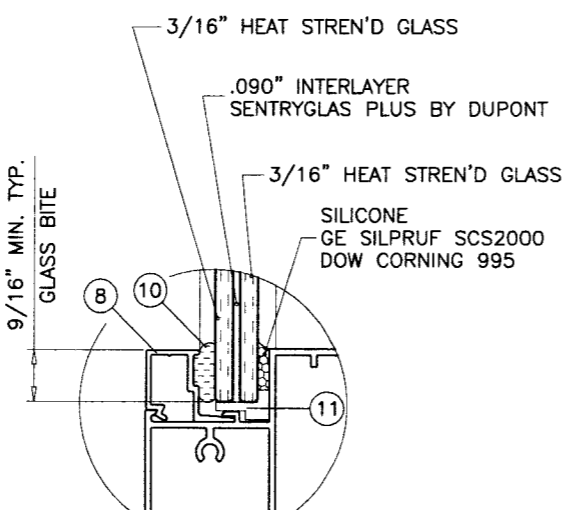

GLASS TYPE 'F'

GLAZING OPTIONS

| WINDOW DIMS. |                  | DESIGN LOAD CAPACITY - PSF |         |                       |         |                          |         |
|--------------|------------------|----------------------------|---------|-----------------------|---------|--------------------------|---------|
| WIDTH        | HEIGHT           | GLASS TYPES 'A' & 'B' **   |         | GLASS TYPES 'C' & 'D' |         | GLASS TYPES 'E' & 'F' ** |         |
|              |                  | EXT.(+)                    | INT.(-) | EXT.(+)               | INT.(-) | EXT.(+)                  | INT.(-) |
| 26-1/2"      | 38-3/8"<br>(4) * | 86.7                       | 100.0   | 80.0                  | 80.0    | 86.7                     | 100.0   |
| 37"          |                  | 86.7                       | 100.0   | 80.0                  | 80.0    | 86.7                     | 100.0   |
| 40"          |                  | 86.7                       | 100.0   | 80.0                  | 80.0    | 86.7                     | 100.0   |
| 48"          |                  | 86.7                       | 100.0   | 80.0                  | 80.0    | 86.7                     | 100.0   |
| 53-1/8"      |                  | 86.7                       | 100.0   | 80.0                  | 80.0    | 86.7                     | 100.0   |
| 26-1/2"      | 50-5/8"<br>(6)   | 86.7                       | 100.0   | 80.0                  | 80.0    | 86.7                     | 100.0   |
| 37"          |                  | 86.7                       | 100.0   | 80.0                  | 80.0    | 86.7                     | 100.0   |
| 40"          |                  | 86.7                       | 100.0   | 80.0                  | 80.0    | 86.7                     | 100.0   |
| 48"          |                  | 86.7                       | 100.0   | 80.0                  | 80.0    | 86.7                     | 100.0   |
| 53-1/8"      |                  | 86.7                       | 100.0   | 80.0                  | 80.0    | 86.7                     | 100.0   |
| 26-1/2"      | 60"<br>(6)       | 86.7                       | 100.0   | 80.0                  | 80.0    | 86.7                     | 100.0   |
| 37"          |                  | 86.7                       | 100.0   | 80.0                  | 80.0    | 86.7                     | 100.0   |
| 40"          |                  | 86.7                       | 100.0   | 80.0                  | 80.0    | 86.7                     | 100.0   |
| 48"          |                  | 86.7                       | 100.0   | 80.0                  | 80.0    | 86.7                     | 100.0   |
| 53-1/8"      |                  | 86.7                       | 100.0   | 80.0                  | 80.0    | 86.7                     | 100.0   |
| 26-1/2"      | 63"<br>(7)       | 86.7                       | 100.0   | 80.0                  | 80.0    | 86.7                     | 100.0   |
| 37"          |                  | 86.7                       | 100.0   | 80.0                  | 80.0    | 86.7                     | 100.0   |
| 40"          |                  | 86.7                       | 100.0   | 80.0                  | 80.0    | 86.7                     | 100.0   |
| 48"          |                  | 86.7                       | 100.0   | 80.0                  | 80.0    | 86.7                     | 100.0   |
| 53-1/8"      |                  | 86.7                       | 100.0   | 80.0                  | 80.0    | 86.7                     | 100.0   |
| 26-1/2"      | 73"<br>(8)       | 86.7                       | 100.0   | 80.0                  | 80.0    | 86.7                     | 100.0   |
| 37"          |                  | 86.7                       | 100.0   | 80.0                  | 80.0    | 86.7                     | 100.0   |
| 40"          |                  | 86.7                       | 100.0   | 80.0                  | 80.0    | 86.7                     | 100.0   |
| 48"          |                  | 86.7                       | 100.0   | 80.0                  | 80.0    | 86.7                     | 100.0   |
| 53-1/8"      |                  | 86.7                       | 92.4    | 80.0                  | 80.0    | 86.7                     | 100.0   |
| 26-1/2"      | 76"<br>(8)       | 86.7                       | 100.0   | 80.0                  | 80.0    | 86.7                     | 100.0   |
| 37"          |                  | 86.7                       | 100.0   | 80.0                  | 80.0    | 86.7                     | 100.0   |
| 40"          |                  | 86.7                       | 100.0   | 80.0                  | 80.0    | 86.7                     | 100.0   |
| 48"          |                  | 86.7                       | 100.0   | 80.0                  | 80.0    | 86.7                     | 100.0   |
| 53-1/8"      |                  | 86.7                       | 100.0   | 80.0                  | 80.0    | 86.7                     | 100.0   |
| 26-1/2"      | 80"<br>(8)       | 86.7                       | 100.0   | 80.0                  | 80.0    | 86.7                     | 100.0   |
| 37"          |                  | 86.7                       | 100.0   | 80.0                  | 80.0    | 86.7                     | 100.0   |
| 40"          |                  | 86.7                       | 100.0   | 80.0                  | 80.0    | 86.7                     | 100.0   |
| 48"          |                  | 86.7                       | 100.0   | 80.0                  | 80.0    | 86.7                     | 100.0   |
| 53-1/8"      |                  | 86.7                       | 100.0   | 80.0                  | 80.0    | 86.7                     | 100.0   |
| 26-1/2"      | 84"<br>(9)       | 86.7                       | 100.0   | 80.0                  | 80.0    | 86.7                     | 100.0   |
| 37"          |                  | 86.7                       | 100.0   | 80.0                  | 80.0    | 86.7                     | 100.0   |
| 40"          |                  | 86.7                       | 100.0   | 80.0                  | 80.0    | 86.7                     | 100.0   |
| 48"          |                  | 86.7                       | 100.0   | 80.0                  | 80.0    | 86.7                     | 100.0   |

\* NO. IN PARENTHESIS INDICATE NO. OF ANCHORS PER JAMB.

\*\* GLASS TYPES 'A' 'B' 'E' & 'F' USE EXT.(+) LOADS 90.0 PSF FOR INSTALLATIONS WHERE WATER INFILTRATION RESISTANCE IS NOT REQD.

NOTE:  
GLASS CAPACITIES ON THIS SHEET ARE BASED ON  
A: ASTM E1300-98 (60 SEC. WIND)  
B: ASTM E1300-02 (3 SEC. GUSTS) WITH REDUCTIONS FOR FLEXIBLE SUPPORTS TO COMPLY WITH SECTION 2403.2 OF FBC 2004 EDITION.

Engr. DR. HUMAYOUN FAROOQ  
STRUCTURES  
FLA. PE # 16557  
C.A.N. 3538

AUG 07 2006

Approved as complying with the  
Florida Building Code  
Date: MARCH 15 2007  
NOA# 06-0911.02  
Miami Dade Product Control  
Division  
By: Manuel Perez

**afc**

**AL-FAROOQ CORPORATION**  
ENGINEERS, PLANNERS & PRODUCT DESIGN  
1235 SW 87 AVE  
MIAMI, FLORIDA 33174  
TEL. (305) 264-8100 FAX. (305) 262-6978  
COMP-ANL\W06-16SAT

SERIES 535 ALUMINUM SINGLE HUNG WDW. (L.M.I.)

**SOL-A-TROL ALUMINUM PRODUCTS**  
4101 N.W. 132ND STREET  
MIAMI, FL. 33054  
TEL. (305) 681-2020 FAX. (305) 681-2035

|            |    |      |    |             |
|------------|----|------|----|-------------|
| revisions: | no | date | by | description |
|            |    |      |    |             |

date: 03-05-06  
scale: 1/2" = 1"  
dr. by: HAMID  
chk. by:

drawing no. **W06-16**  
sheet 2 of 7

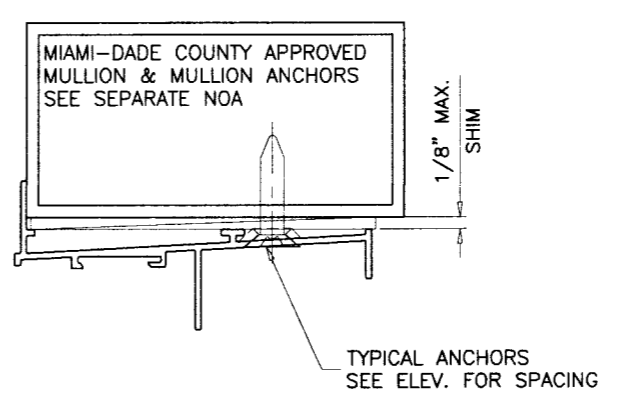
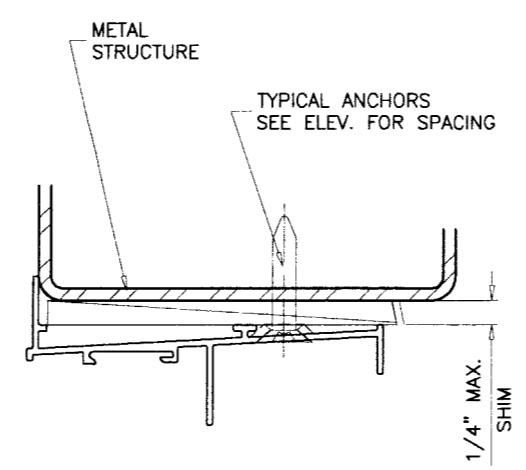
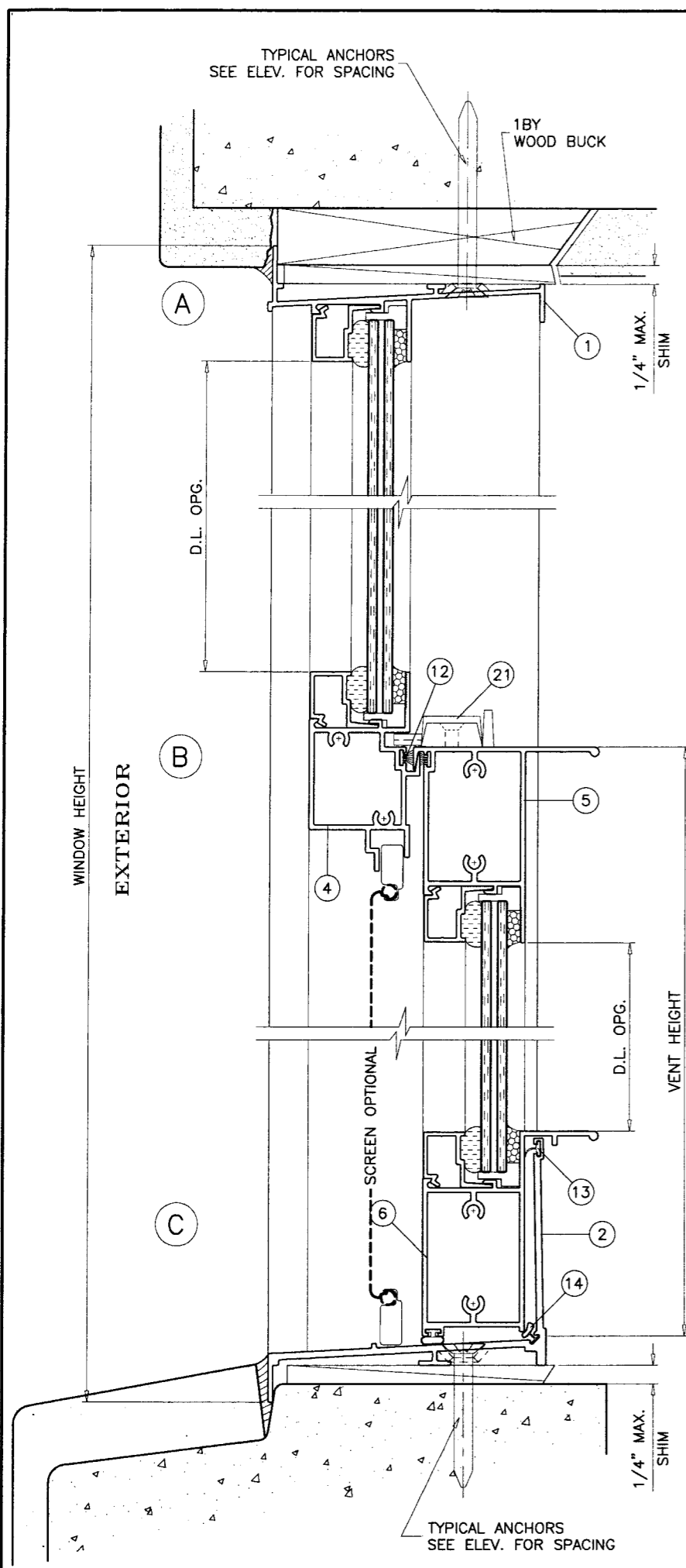

WOOD BUCKS AND METAL STRUCTURE NOT BY SOL-A-TROL MUST SUSTAIN LOADS IMPOSED BY GLAZING SYSTEM AND TRANSFER THEM TO THE BUILDING STRUCTURE.

**TYPICAL ANCHORS:** SEE ELEV. FOR SPACING

**1/4" TAPCONS**  
 INTO 2BY WOOD BUCKS OR WOOD STRUCTURES  
 1-1/2" MIN. PENETRATION INTO WOOD

THRU 1BY BUCKS INTO CONC. OR MASONRY  
 1-1/4" MIN. EMBED INTO CONC. OR MASONRY  
 DIRECTLY INTO CONC. OR MASONRY  
 1-1/4" MIN. EMBED INTO CONC. OR MASONRY

**#14 SMS OR SELF DRILLING SCREWS**  
 INTO METAL STRUCTURES  
 STEEL : 12 GA. MIN. (Fy = 36 KSI MIN.)  
 ALUMINUM : 1/8" THK. MIN. (6063-T5 MIN.)  
 (STEEL IN CONTACT WITH ALUMINUM TO BE PLATED OR PAINTED)

**#12 SMS OR SELF DRILLING SCREWS**  
 INTO DADE COUNTY APPROVED MULLIONS (MIN. THK. = .090")  
 (1/8" SHIM SPACE)

**TYPICAL EDGE DISTANCE**  
 INTO CONCRETE AND MASONRY = 1-1/2" MIN.  
 INTO WOOD STRUCTURE = 1" MIN.  
 INTO METAL STRUCTURE = 1/2" MIN.

**SEALANTS:**  
 ALL JOINTS AND FRAME CONNECTIONS SEALED WITH SCHNEE MOREHEAD SEAM SEALER.

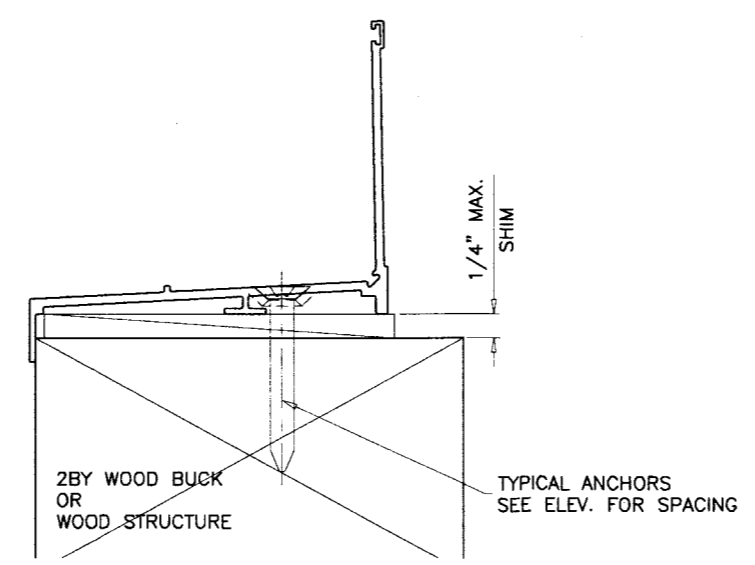

Engr. DR. HUMAYOUN FAROOQ  
 STRUCTURES  
 FLA. PE # 16557  
 C.A.N. 3538

Approved as complying with the  
 Florida Building Code  
 Date: MARCH 15, 2007  
 NOA# 06-0911.02  
 Miami Dade Product Control  
 Division  
 By: Manuel Perez

**afc**

**AL-FAROOQ CORPORATION**  
 ENGINEERS, PLANNERS & PRODUCT DESIGN  
 1235 SW 87 AVE  
 MIAMI, FLORIDA 33174  
 TEL. (305) 264-8100 FAX. (305) 262-6978  
 COMP-ANL\W06-16SAT

---

SERIES 535 ALUMINUM SINGLE HUNG WDW. (L.M.I.)

**SOL-A-TROL ALUMINUM PRODUCTS**  
 4101 N.W. 132ND STREET  
 MIAMI, FL. 33054  
 TEL. (305) 681-2020 FAX. (305) 681-2035

| revisions: | no | date | description |
|------------|----|------|-------------|
|            |    |      |             |
|            |    |      |             |
|            |    |      |             |

---

date: 03-05-06  
 scale: 1/2" = 1"  
 dr. by: HAMID  
 chk. by:  

---

drawing no. **W06-16**  
 sheet 3 of 7

| ITEM # | PART #        | REQD.      | DESCRIPTION                    | MATERIAL  | MANF./SUPPLIER/REMARKS                     |
|--------|---------------|------------|--------------------------------|-----------|--|
| 1      | ARSO-954      | 1          | FRAME HEAD                     | 6063-T6   | -  |
| 2      | ARSO-958      | 1          | FRAME SILL                     | 6063-T6   | -  |
| 3      | ARSO-955      | 2          | FRAME JAMB                     | 6063-T6   | -  |
| 4      | ARSO-959      | 1          | FIXED MTG. RAIL                | 6063-T6   | -  |
| 5      | ARSO-956      | 1          | VENT TOP RAIL                  | 6063-T6   | -  |
| 6      | ARSO-951      | 1          | VENT BOTTOM RAIL               | 6063-T6   | -  |
| 7      | ARSO-960      | 2          | VENT SIDE RAIL                 | 6063-T5   | -  |
| 8      | ARSO-953      | AS REQD.   | GLAZING BEAD                   | 6063-T6   | -  |
| 9      | -             | AS REQD.   | ANCHOR CLIP, 2" LONG           | 6063-T6   | -  |
| 10     | FP-40         | AS REQD.   | GLAZING WEDGE                  | VINYL     | PROTOTYPE PLASTICS                         |
| 11     | 326-FP-894B   | AS REQD.   | SETTING BLOCK                  | VINYL     | PROTOTYPE PLASTICS                         |
| 12     | 00935-18701   | AS REQD.   | PILE W'STRIPPING               | -         | POLYPILE                                   |
| 13     | 326-FP-150S-B | AS REQD.   | FLAP W'STRIPPING               | VINYL     | PROTOTYPE PLASTICS                         |
| 14     | 326-FP-216SB  | AS REQD.   | BULB W'STRIPPING               | VINYL     | PROTOTYPE PLASTICS                         |
| 15     | 326-FP-261AB  | AS REQD.   | BOTTOM RAIL BULB W'STRIPPING   | VINYL     | PROTOTYPE PLASTICS                         |
| 16     | LL-50         | 2/VENT     | SPIRAL BALANCE                 | -         | UNIQUE BALANCE                             |
| 17     | FBBSS8CFD3    | 1/ BALANCE | BALANCE HOOK                   | -         | UNIQUE BALANCE                             |
| 18     | -             | 2          | SASH TOP GUIDE                 | -         | M&M PLASTICS                               |
| 19     | FG-200        | 2          | SASH FACE GUIDE                | PLASTIC   | M&M PLASTICS                               |
| 20     | -             | -          | -                              | -         | -  |
| 21     | 672205K38     | 2/VENT     | SWEEP LOCK AT 9-7/8" FROM ENDS | ZINC      | DECO PRODUCTS, SECURED W/ (2) #8X1" FH SMS |
| 22     | #10 X 1"      | AS REQD.   | FRAME & VENT ASSEMBLY SCREWS   | ST. STEEL | PH SMS                                     |
| 23     | -             | AS REQD.   | U-CHANNEL                      | ALUMINUM  | -  |
| 24     | ARSO-979      | AS REQD.   | STRAP                          | 6063-T5   | -  |

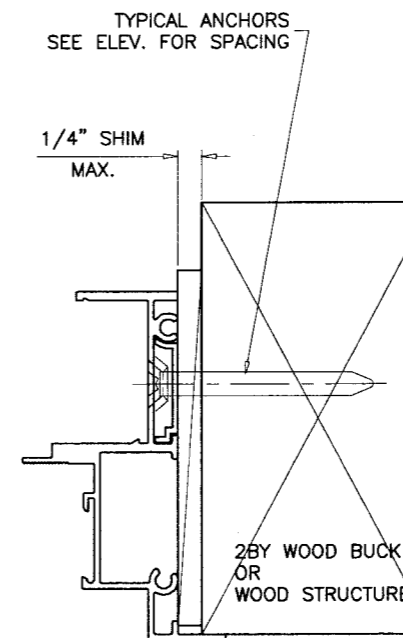
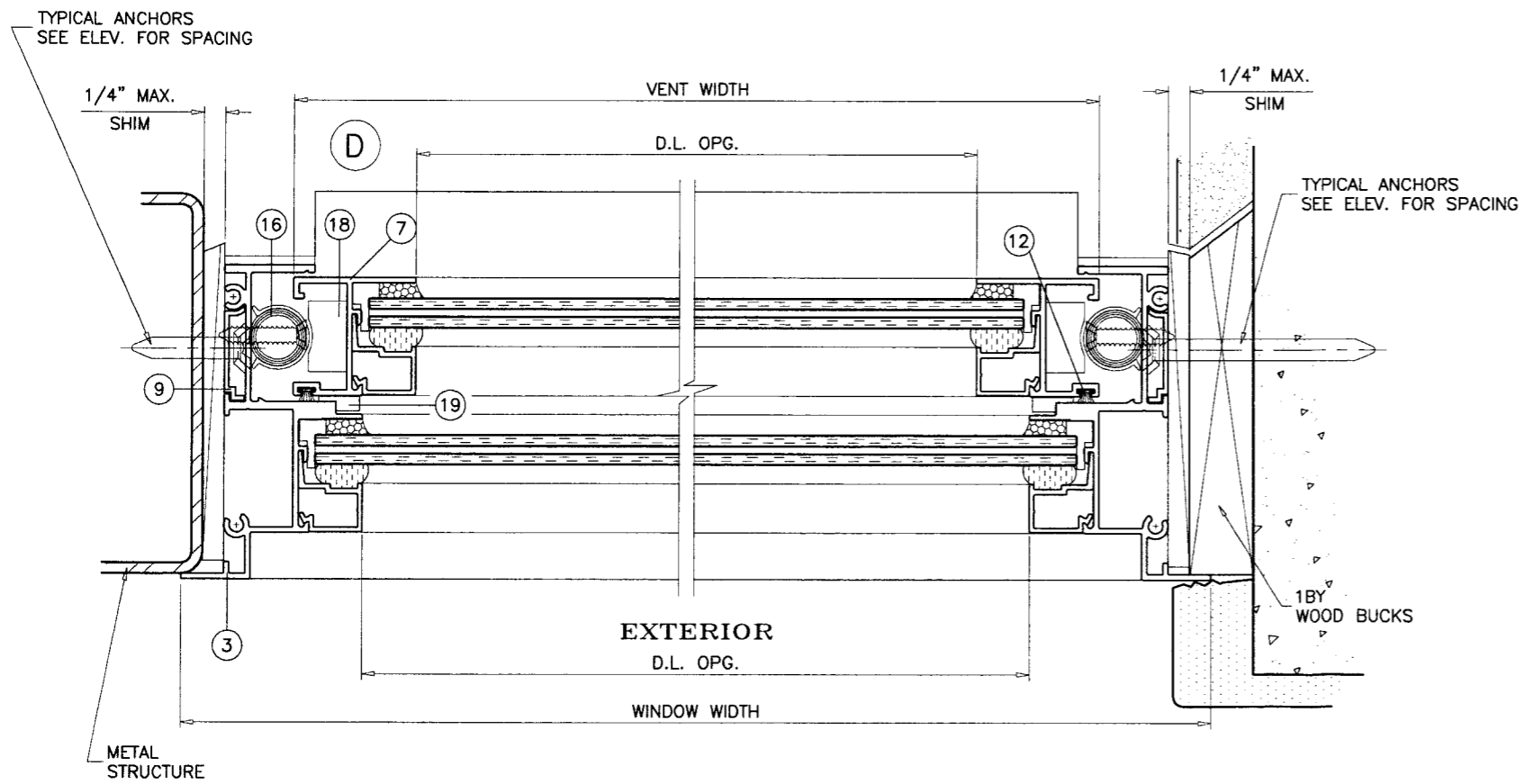

Engr: DR. HUMAYOUN FAROOQ  
STRUCTURES  
FLA. PE # 16557  
C.A.N. 3538

Approved as complying with the  
Florida Building Code  
Date MARCH 15, 2007  
NOA# 06-0911-02  
Miami Dade Product Control  
Division  
By Manuel Perez

**AL-FAROOQ CORPORATION**  
ENGINEERS, PLANNERS & PRODUCT DESIGN  
1235 SW 87 AVE  
MIAMI, FLORIDA 33174  
TEL. (305) 264-8100 FAX. (305) 262-6978  
COMP-ANL\W06-16SAT

SERIES 535 ALUMINUM SINGLE HUNG WDW. (L.M.I.)  
**SOL-A-TROL ALUMINUM PRODUCTS**  
4101 N.W. 132ND STREET  
MIAMI, FL. 33054  
TEL. (305) 681-2020 FAX. (305) 681-2035

| revisions: | no | date | by | description |
|------------|----|------|----|-------------|
|            |    |      |    |             |
|            |    |      |    |             |
|            |    |      |    |             |
|            |    |      |    |             |

date: 03-05-06  
scale: 1/2" = 1"  
dr. by: HAMID  
chk. by:

drawing no.  
**W06-16**  
sheet 4 of 7

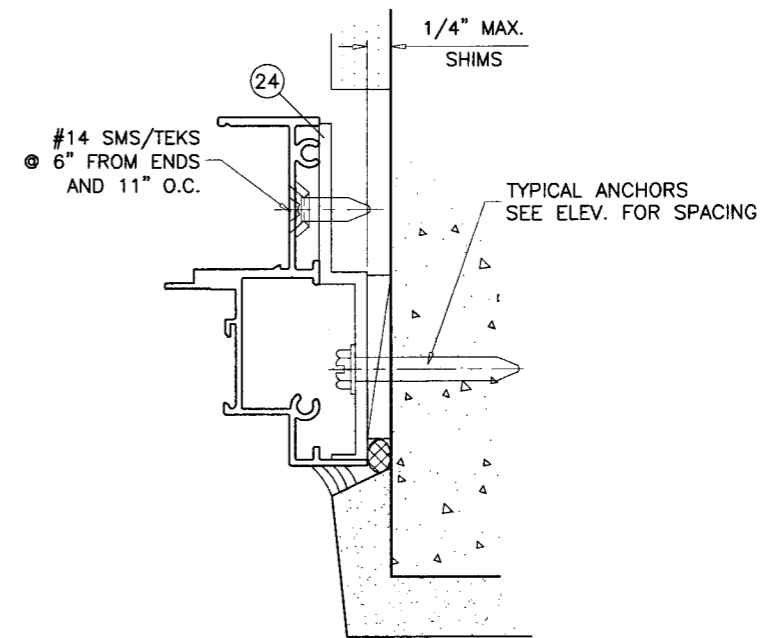
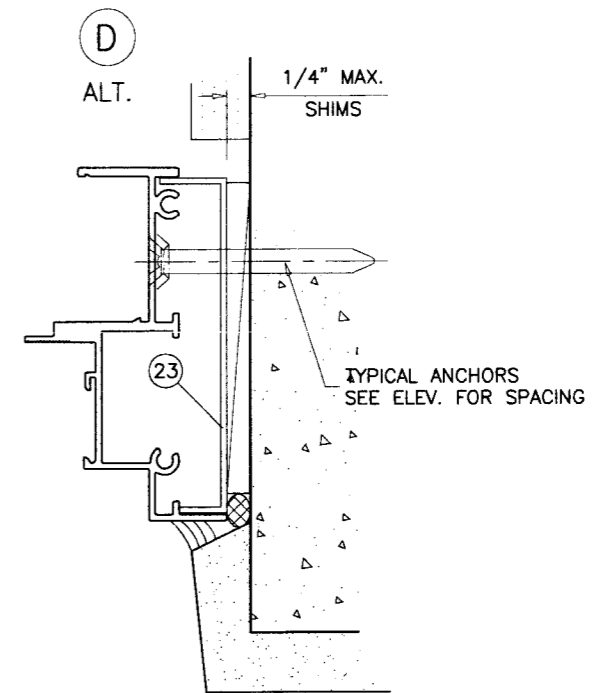
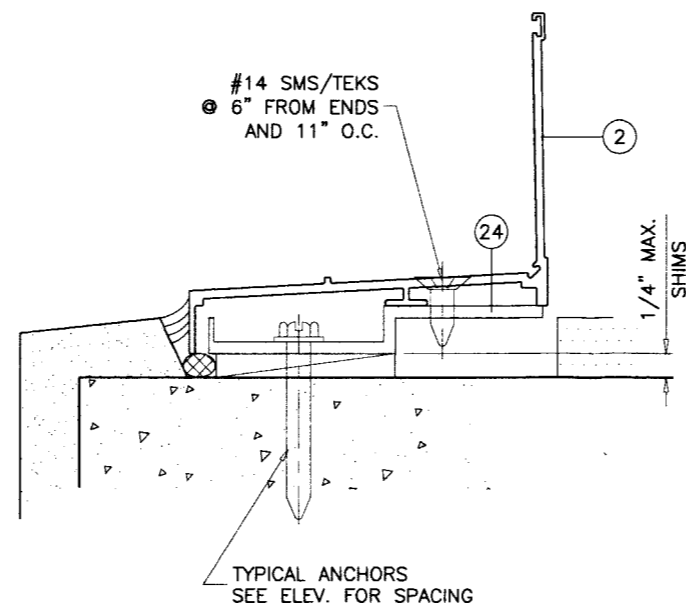
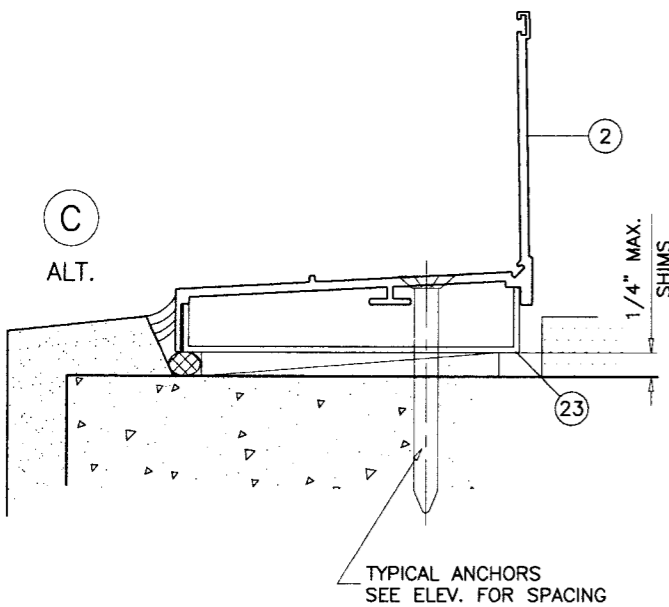
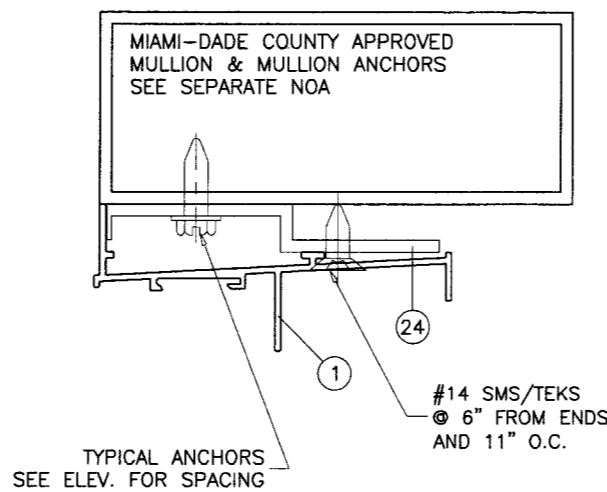
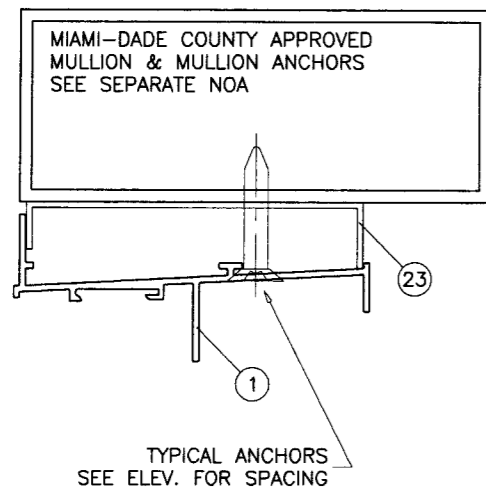
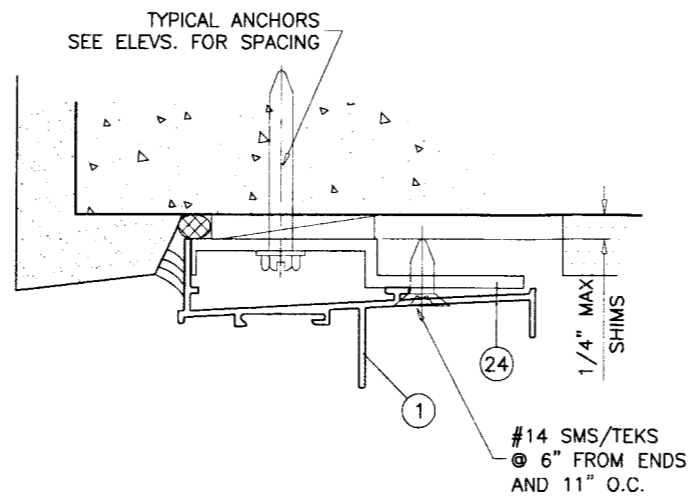
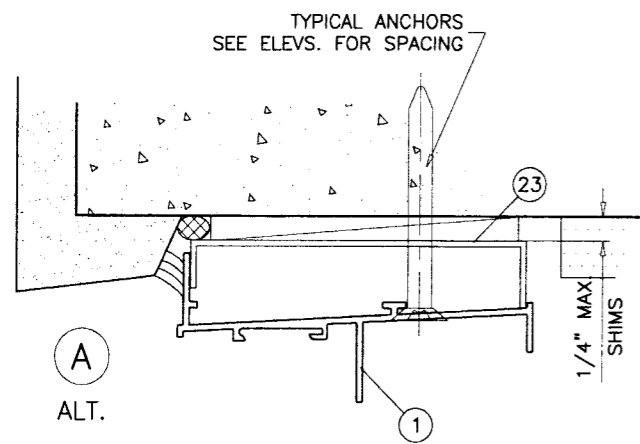

INSTALLATION DETAILS WITH CHANNEL & STRAP

Engr. DR. HUMAYOUN FAROOQ  
STRUCTURES  
FLA. PE # 16557  
C.A.N. 3538

AUG 17 2006

Approved as complying with the  
Florida Building Code  
Date **MARCH 15, 2007**  
NOA# **06-0911.02**  
Miami Dade Product Control  
Division  
By *Manuel Perez*

afc

**AL-FAROOQ CORPORATION**  
ENGINEERS, PLANNERS & PRODUCT DESIGN  
1235 SW 87 AVE  
MIAMI, FLORIDA 33174  
TEL. (305) 264-8100 FAX. (305) 262-6978  
COMP-ANL\W06-16SAT

SERIES 535 ALUMINUM SINGLE HUNG WDW. (L.M.I.)  
**SOL-A-TROL ALUMINUM PRODUCTS**  
4101 N.W. 132ND STREET  
MIAMI, FL. 33054  
TEL. (305) 681-2020 FAX. (305) 681-2035

| no | date | description |
|----|------|-------------|
|    |      |             |
|    |      |             |
|    |      |             |
|    |      |             |

date: 03-05-06  
scale: 1/2" = 1"  
dr. by: HAMID  
chk. by:

drawing no.  
**W06-16**  
sheet 5 of 7

| MULLION LOAD CAPACITY - PSF |            |                    |                    |
|-----------------------------|------------|--------------------|--------------------|
| WINDOW DIMS.                |            | TYPE '1'           | TYPE '2'           |
| WIDTH (W)                   | LENGTH (L) | EXT.(+)<br>INT.(-) | EXT.(+)<br>INT.(-) |
| 26-1/2"                     | 38-3/8"    | 100.0              | 100.0              |
| 32"                         |            | 100.0              | 100.0              |
| 37"                         |            | 100.0              | 100.0              |
| 42"                         |            | 100.0              | 100.0              |
| 48"                         |            | 100.0              | 100.0              |
| 53-1/8"                     |            | 100.0              | 100.0              |
| 26-1/2"                     | 50-5/8"    | 100.0              | 100.0              |
| 32"                         |            | 100.0              | 100.0              |
| 37"                         |            | 100.0              | 100.0              |
| 42"                         |            | 100.0              | 100.0              |
| 48"                         |            | 100.0              | 100.0              |
| 53-1/8"                     |            | 100.0              | 100.0              |
| 26-1/2"                     | 60"        | 100.0              | 100.0              |
| 32"                         |            | 100.0              | 100.0              |
| 37"                         |            | 100.0              | 100.0              |
| 42"                         |            | 100.0              | 100.0              |
| 48"                         |            | 100.0              | 100.0              |
| 53-1/8"                     |            | 100.0              | 100.0              |
| 26-1/2"                     | 63"        | 100.0              | 100.0              |
| 32"                         |            | 100.0              | 100.0              |
| 37"                         |            | 100.0              | 100.0              |
| 42"                         |            | 100.0              | 100.0              |
| 48"                         |            | 100.0              | 100.0              |
| 53-1/8"                     |            | 100.0              | 100.0              |
| 26-1/2"                     | 74"        | 100.0              | 100.0              |
| 32"                         |            | 100.0              | 100.0              |
| 37"                         |            | 100.0              | 100.0              |
| 42"                         |            | 100.0              | 100.0              |
| 48"                         |            | 100.0              | 100.0              |
| 53-1/8"                     |            | 100.0              | 100.0              |
| 26-1/2"                     | 80"        | 100.0              | 100.0              |
| 32"                         |            | 100.0              | 100.0              |
| 37"                         |            | 100.0              | 100.0              |
| 42"                         |            | 100.0              | 100.0              |
| 48"                         |            | 95.2               | 100.0              |
| 53-1/8"                     |            | 86.2               | 100.0              |

**NOTES:**

- USE CHART ON THIS SHEET FOR SIDE BY SIDE CONNECTION CAPACITY OF WINDOW MULLION.
- FOR FIXED WINDOW CAPACITY SEE SHEET 2 OF 7.
- LOWER VALUES FROM STEPS 1 OR 2 WILL APPLY TO ENTIRE SYSTEM.

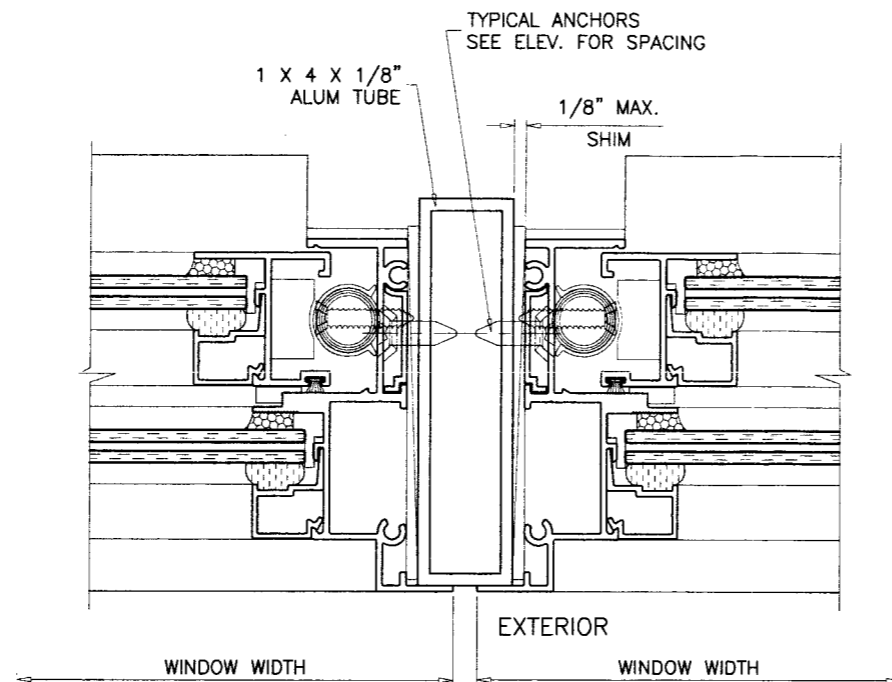

**MULLION TYPE '1'**

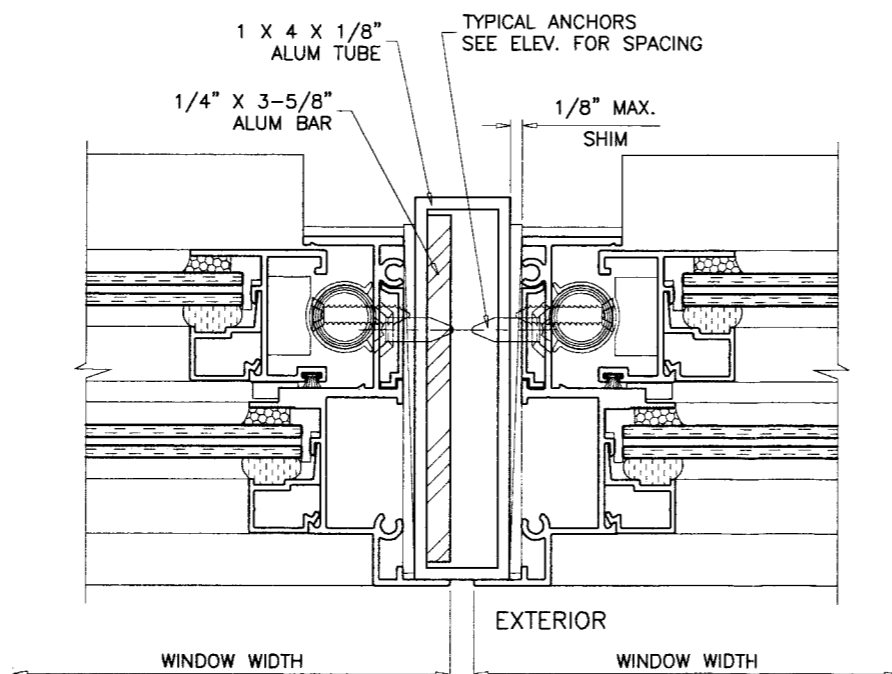

**MULLION TYPE '2'**

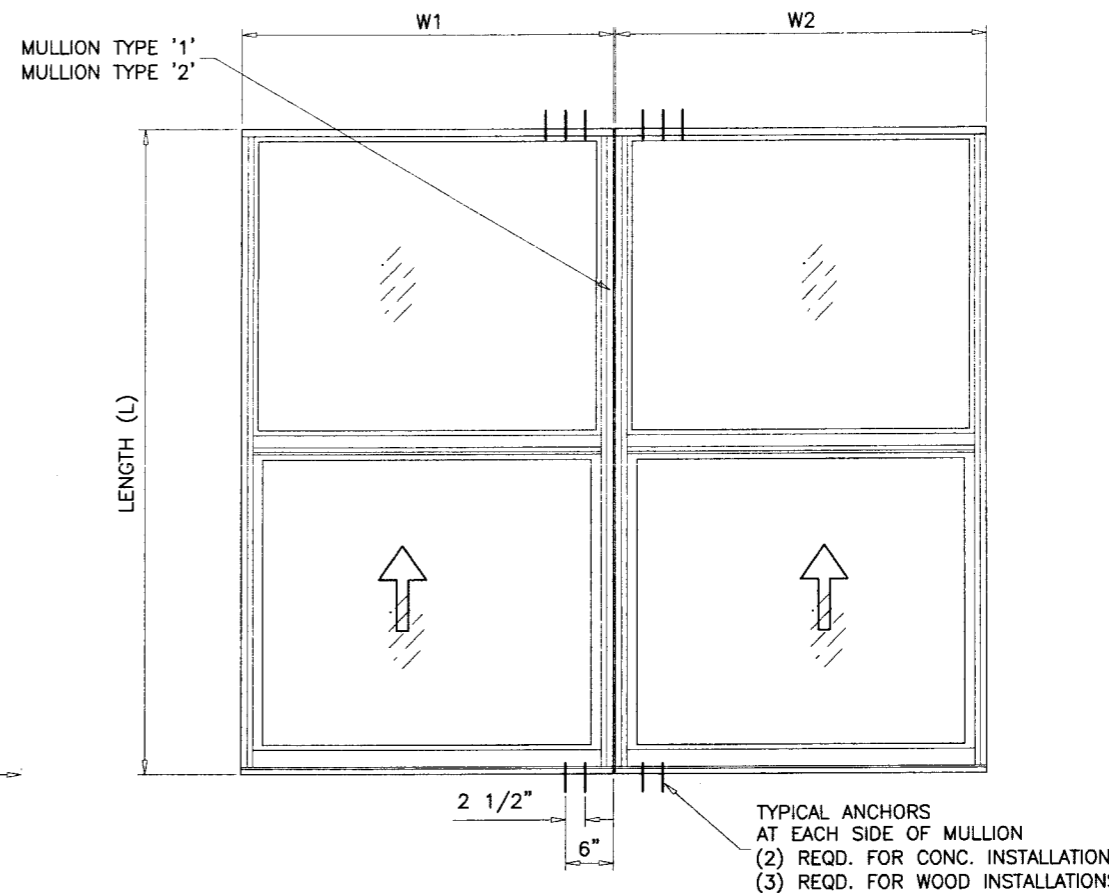

**TYPICAL ELEVATIONS**  
SIDE BY SIDE WINDOWS  
SIDE BY SIDE APPLIES TO TWO OR MORE WINDOWS

$$\text{WIDTH (W)} = \frac{W1 + W2}{2}$$

Engr: DR. HUMAYOON FAROOQ  
STRUCTURES  
FLA. PE # 16557  
C.A.N. 3538

AUG 07 2006

Approved as complying with the  
Florida Building Code  
Date: MARCH 13 2007  
NOAE 06-0911-02  
Miami Dade Product Control  
Division  
By: *Manuel Perez*

**AL-FAROQ CORPORATION**  
ENGINEERS, PLANNERS & PRODUCT DESIGN  
1235 SW 87 AVE  
MIAMI, FLORIDA 33174  
TEL. (305) 264-8100 FAX. (305) 262-6978  
COMP-ANL\W06-16SAT

SERIES 535 ALUMINUM SINGLE HUNG WDW. (L.M.I.)  
**SOL-A-TROL ALUMINUM PRODUCTS**  
4101 N.W. 132ND STREET  
MIAMI, FL. 33054  
TEL. (305) 681-2020 FAX. (305) 681-2035

| revisions: | no | date | by | description |
|------------|----|------|----|-------------|
|            |    |      |    |             |
|            |    |      |    |             |
|            |    |      |    |             |

date: 03-05-06  
scale: 1/2" = 1"  
dr. by: HAMID  
chk. by:

drawing no.  
**W06-16**  
sheet 6 of 7

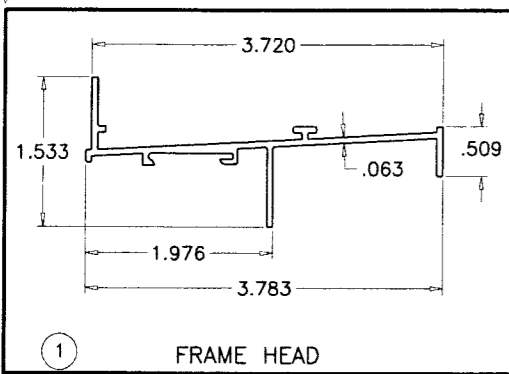

1 FRAME HEAD

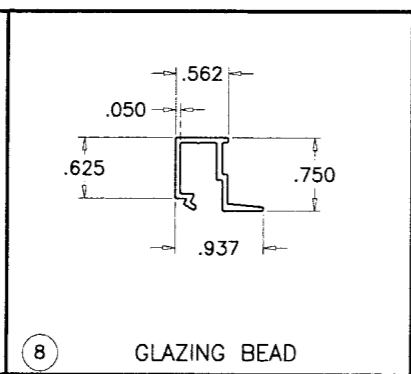

8 GLAZING BEAD

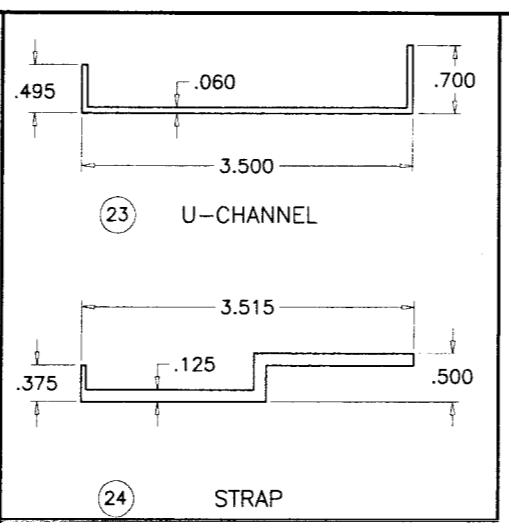

23 U-CHANNEL

24 STRAP

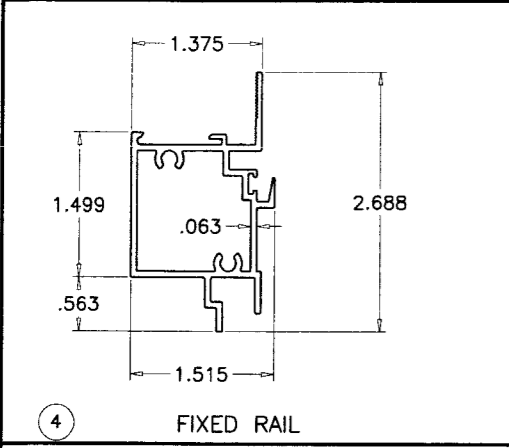

4 FIXED RAIL

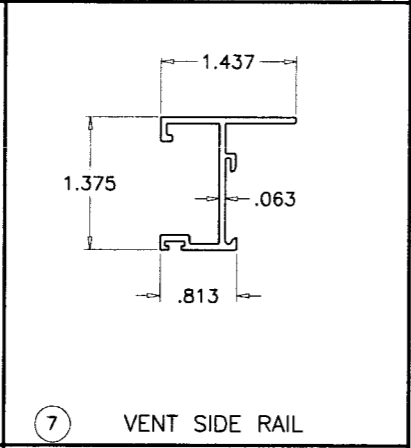

7 VENT SIDE RAIL

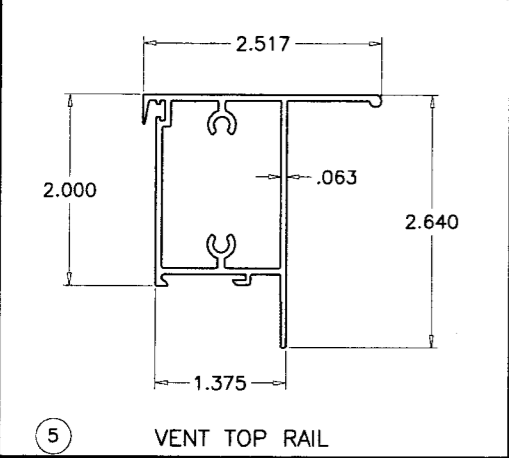

5 VENT TOP RAIL

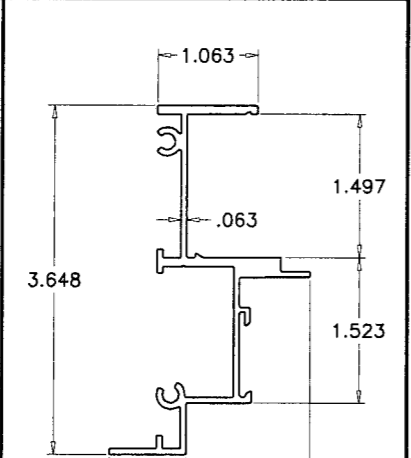

3 FRAME JAMB

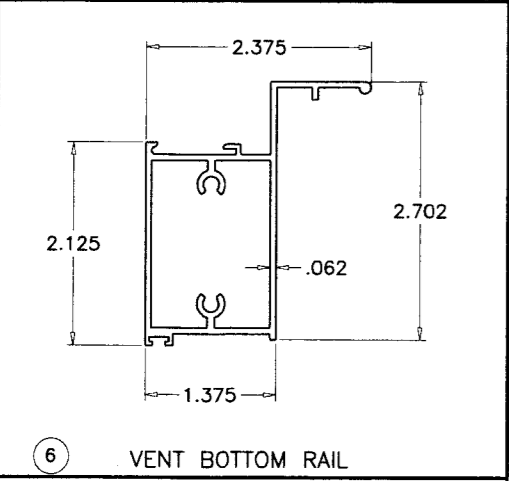

6 VENT BOTTOM RAIL

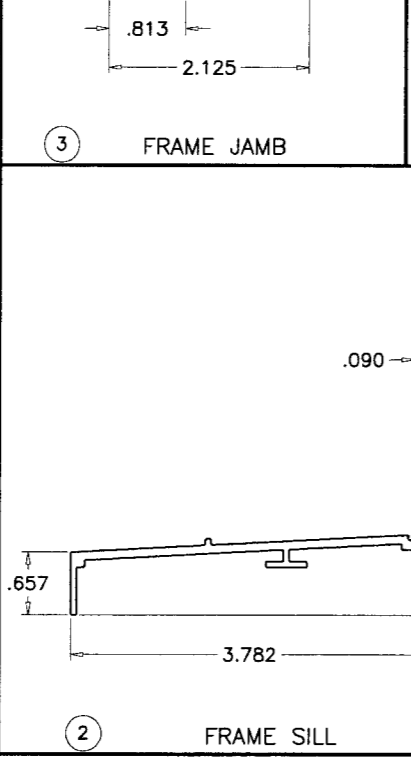

2 FRAME SILL

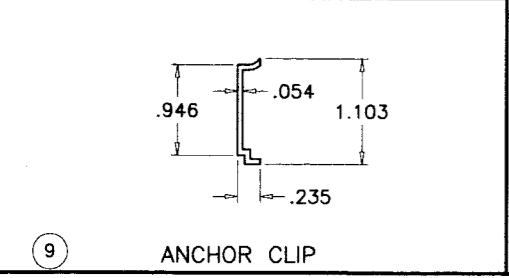

9 ANCHOR CLIP

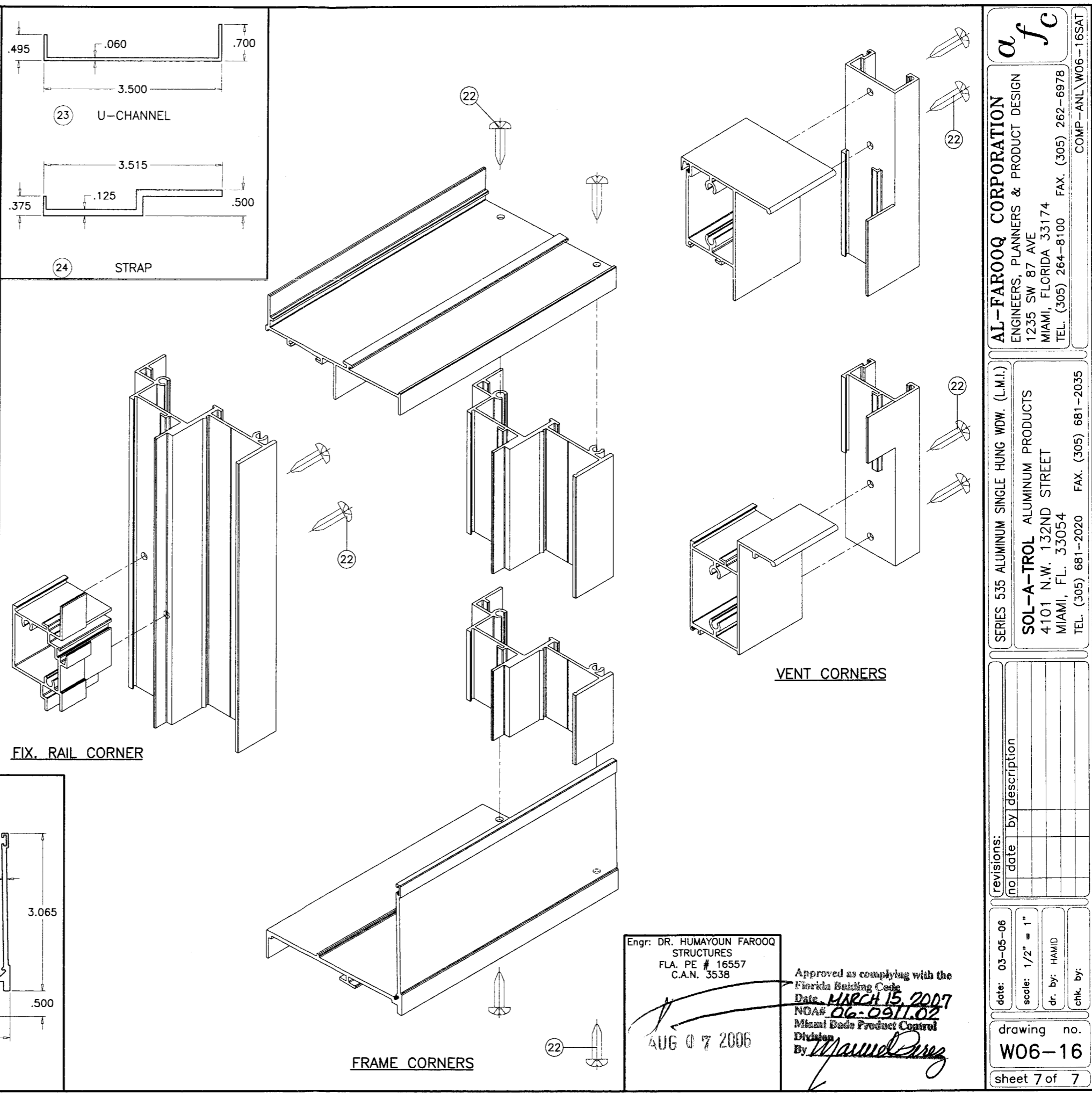

FIX. RAIL CORNER

FRAME CORNERS

VENT CORNERS

Engr: DR. HUMAYOUN FAROOQ  
STRUCTURES  
FLA. PE # 16557  
C.A.N. 3538

Approved as complying with the  
Florida Building Code  
Date: MARCH 15, 2007  
NOA# 06-0911.02  
Miami Dade Product Control  
Division  
By: Mamad Drez

AUG 07 2006

**afc**

**AL-FAROOQ CORPORATION**  
ENGINEERS, PLANNERS & PRODUCT DESIGN  
1235 SW 87 AVE  
MIAMI, FLORIDA 33174  
TEL. (305) 264-8100 FAX. (305) 262-6978  
COMP-ANL\W06-16SAT

---

SERIES 535 ALUMINUM SINGLE HUNG WDW. (L.M.I.)

**SOL-A-TROL ALUMINUM PRODUCTS**  
4101 N.W. 132ND STREET  
MIAMI, FL. 33054  
TEL. (305) 681-2020 FAX. (305) 681-2035

| revisions: | no | date | by | description |
|------------|----|------|----|-------------|
|            |    |      |    |             |
|            |    |      |    |             |
|            |    |      |    |             |

date: 03-05-06  
scale: 1/2" = 1"  
dr. by: HAMID  
chk. by:      

drawing no.  
**W06-16**

sheet 7 of 7